

# 1.5 mL Microcentrifuge Tube

MLS-MCT-15NA



### Description

1.5 mL Microcentrifuge Tube, Low Retention, Clear, Non-Sterile

### Materials

Tube: PP (Polypropylene)  
Cap: PP (Polypropylene)

### Features

- ❖ Graduation markings
- ❖ Max fill: 1.7 mL
- ❖ Autoclavable: 15 psi 121°C for 15 minutes
- ❖ Shelf life: 3 years from date manufactured
- ❖ Boil-proof caps are ideal for rigorous high temp applications and tight storage conditions
- ❖ Crystal-clear polymer facilitates visualization of samples
- ❖ Rated to 20,000 x G
- ❖ Temperature range: -80°C to +121°C
- ❖ Certified free of detectable RNase, DNase, DNA, PCR inhibitors, and tested pyrogen-free

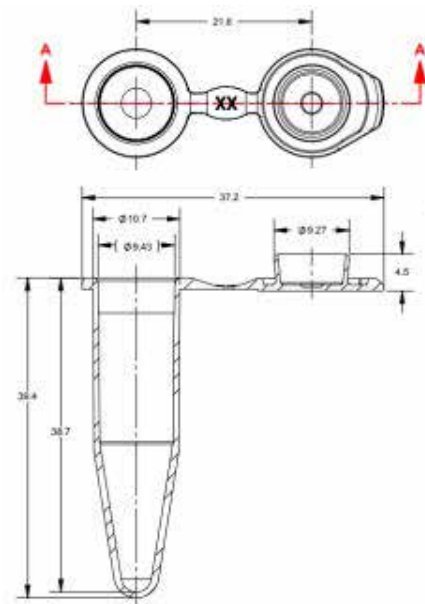

Item No.	Item	Sterile	Packaging Configuration
MLS-MCT-15NA	1.5 mL Microcentrifuge Tube, Low Retention	No	250/pack 10 packs/case